

4N-SM13X0

1.25Gbps 9/125µm BiDi SFP Mini-GBIC Optical Transceiver

Single-Mode 10Km/20Km DDMI 1310nm

4N-SM1310 : 10Km

4N-SM1320 : 20Km



1. Feature:

- SFP package with LC connector (Duplex)
- 1310nm FP Laser PIN photodetector
- 1550nm DFB Laser PIN photodetector
- Up to 10Km / 20Km transmission on SMF
- +3.3V single power supply
- Supports working with Media Converter and Switch with SFP port.
- Low EMI and excellent ESD protection
- Hot-Pluggable / Hot-Swappable
- Class 1 laser safety standard IEC-60825-1 compliant
- Compatible with RoHS
- DDMI (Digital Diagnostic Monitoring Interface)
- Certifications : FCC Part 15 Class B & CE Approved
- Compliant with EN 55022 and EN 61000-3 series

2. Application:

- 1.25Gb/s 1000Base-LX Ethernet
- 1.06 Gb/s Fibre Channel Fiber Channel

3. Absolute Maximum Ratings:

Parameter	Symbol	Minimum	Maximum	Units
Storage Temperature	Tst	-40	+85	°C
Supply Voltage	Vcc	0	+3.6	V
Operating Humidity	Relative RH	5	95	%

4. Operation Environment:

Parameter	Symbol	Min	Typical	Max	Units
Supply Voltage	Vcc	3.15	3.3	3.45	V
Operating Case Temperature	TC	0		+70	°C
Power Dissipation				1	W
Data Rate			1.25		Gbps

5. Optical Characteristics:

(Ambient Operating Temperature 0°C to +70°C, Vcc =3.3 V)

(Ambient Operating Storage -40 °C to +85°C, Vcc =3.3 V)

Parameter	Symbol	Min.	Typ.	Max.	Units	
Transmitter Power Section						
Center Wavelength	Tx 1310	λ_o	1260	1310	1360	nm
	Tx 1550		1540	1550	1560	
Spectral Width(RMS)	Tx 1310	$\Delta\lambda$	-	-	4	nm
	Tx 1550				1	
Average Output Power	Tx 1310	Po	-9.0	-	-3	dBm
	Tx 1550		-9.0		-3	
Extinction Ratio	Er	8	-		dB	
Rise/Fall Time(20%~80%)	Tr/Tf			300	ps	
Total jitter	Tj			0.43	UI	
Optical Eye Diagram	IEEE 802.3z and ANSI Fibre Channel Compatible					
Receiver Section						
Center Wavelength	Rx 1550	λ_o	1500	1550	1600	nm
	Rx 1310		1260	1310	1360	
Receiver Sensitivity	Rsen	-23	-23	-23	dBm	
Receiver Overload	Rov	-3			dBm	

Return Loss		12			dB
LOS Assert	LOS _A	-36			dBm
LOS Dessert	LOS _D			-23	dBm
LOS Hysteresis		0.5		5	

6. Electrical Characteristics:

(Ambient Operating Temperature 0°C to +70°C, V_{cc} =3.3 V)

Parameter	Symbol	Min.	Typ.	Max.	unit
Transmitter Section					
Input Differential Impedence	Z _{in}	90	100	110	Ohm
Data Input Swing Differential	V _{in}	500		2400	mV
TX Disable	Disable	2.0		V _{cc}	V
	Enable	0		0.8	V
TX Fault	Assert	2.0		V _{cc}	V
	Deassert	0		0.8	V
Receiver Section					
Output differential impedance	Z _{out}		100		Ohm
Data Input Swing Differential	V _{out}	370		2000	mV
Rx_LOS	Assert	2.0		V _{cc}	V
	Deassert	0		0.8	V

7. EEPROM INFORMATION (A0) :

Addr	Field Size (Bytes)	Name of Field	HEX	Description
0	1	Identifier	03	SFP
1	1	Ext. Identifier	04	MOD4
2	1	Connector	07	LC
3-10	8	Transceiver	00 00 00 02 12 00 0D 01	Transmitter Code
11	1	Encoding	01	8B10B
12	1	BR, nominal	0D	1250M bps
13	1	Reserved	00	

14	1	Length (9um)-km	14	1
15	1	Length (9um)	64/C8/FF	
16	1	Length (50um)	00	
17	1	Length (62.5um)	00	
18	1	Length (copper)	00	
19	1	Reserved	00	
20-35	16	Vendor name	57 49 4E 54 4F 50 20 20 20 20 20 20 20 20 20 20	WINTOP
36	1	Reserved	00	
37-39	3	Vendor OUI	00 00 00	
40-55	16	Vendor PN	xx xx xx xx xx xx xx xx xx xx xx xx xx xx xx xx	ASC II
56-59	4	Vendor rev	31 2E 30 20	V1.0
60-61	2	Wavelength	05 1E/05 D2	1310nm/1550nm
62	1	Reserved	00	
63	1	CC BASE	XX	Check sum of byte 0~62
64-65	2	Options	00 1A	LOS, TX_DISABLE, TX_FAULT
66	1	BR, max	32	50%
67	1	BR, min	32	50%
68-83	16	Vendor SN	00 00 00 00 00 00 00 00 00 00 00 00 00 00 00 00	Unspecified
84-91	8	Vendor date code	XX XX XX 20	Year, Month, Day
92-94	3	Reserved	00	
95	1	CC_EXT	XX	Check sum of byte 64~94
96-255	160	Vendor specific		

8. Diagnostics:

Parameter	Range	Accuracy	Unit	Calibration
Temperature	0 ~ 70	±5	°C	Internal
Voltage	3-15 ~ 3.45	0.1	V	Internal
Bias Current	10 ~ 80	±2	mA	Internal
Tx Power	-9.5 ~ -3	±2	dBm	Internal
Rx Power	-26~-3	±3	dBm	Internal

9. Pin Description:

Pins	Name	Discription	NOTE
1	VeeT	Transmitter Ground	
2	Tx Fault	Transmitter Fault Indication	1
3	Tx Disable	Transmitter Disable	2
4	MOD DEF2	Module Definition 2	3
5	MOD DEF1	Module Definition 1	3
6	MOD DEF0	Module Definition 0	3
7	Rate Select	Not Connected	
8	LOS	Loss of Signal	4
9	VeeR	Receiver Ground	
10	VeeR	Receiver Ground	
11	VeeR	Receiver Ground	
12	RD-	Inv. Received Data Output	5
13	RD+	IReceived Data Output	5
14	VeeR	Receiver Ground	
15	VccR	Receiver Power	
16	VccT	Transmitter Power	
17	VeeT	Transmitter Ground	
18	TD+	Transmit Data Input	6
19	TD-	Inv. Transmit Data Input	6
20	VeeT	Transmitter Ground	

Notes:

- TX Fault is an open collector output, which should be pulled up with a 4.7k~10kΩ resistor on the host board to a voltage between 2.0V and Vcc+0.3V. Logic 0 indicates normal operation; logic 1 indicates a laser fault of some kind. In the low state, the output will be pulled to less than 0.8V.
- TX Disable is an input that is used to shut down the transmitter optical output. It is pulled up within the module with a 4.7k~10kΩ resistor. Its states are:
 Low (0~0.8V): Transmitter on
 (>0.8V, <2.0V): Undefined
 High (2.0~3.3V): Transmitter Disabled
 Open: Transmitter Disabled
- MOD-DEF 0,1,2 are the module definition pins. They should be pulled up with a 4.7k~10kΩ resistor on the host board. The pull-up voltage shall be VccT or VccR.
 MOD-DEF 0 is grounded by the module to indicate that the module is present
 MOD-DEF 1 is the clock line of two wire serial interface for serial ID

MOD-DEF 2 is the data line of two wire serial interface for serial ID

4. LOS is an open collector output, which should be pulled up with a 4.7k~10kΩ resistor on the host board to a voltage between 2.0V and Vcc+0.3V. Logic 0 indicates normal operation; logic 1 indicates loss of signal. In the low state, the output will be pulled to less than 0.8V.
5. These are the differential receiver output. They are internally AC-coupled 100Ω differential lines which should be terminated with 100Ω (differential) at the user SERDES.
6. These are the differential transmitter inputs. They are AC-coupled, differential lines with 100Ω differential termination inside the module.

10. Recommended Application Circuit:

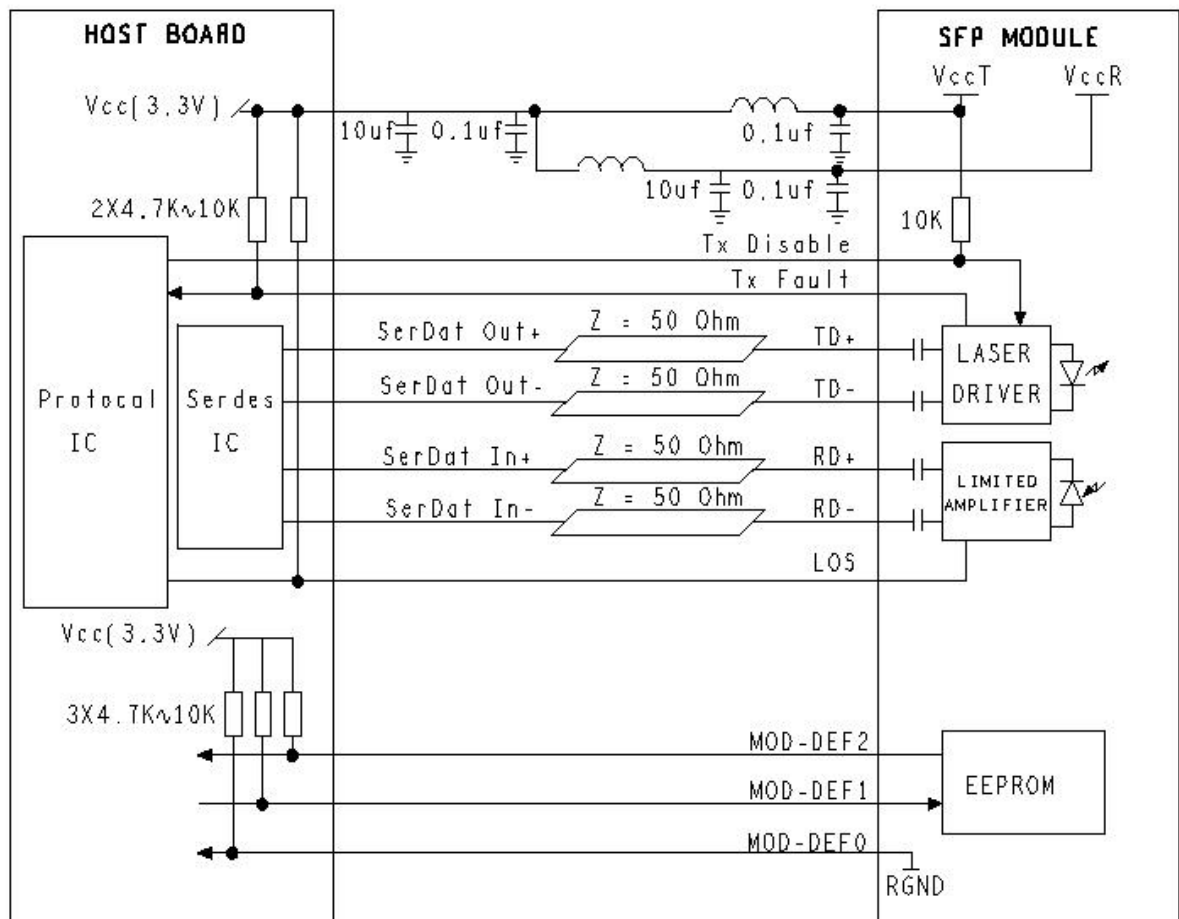

11. Outline Dimensions (mm):

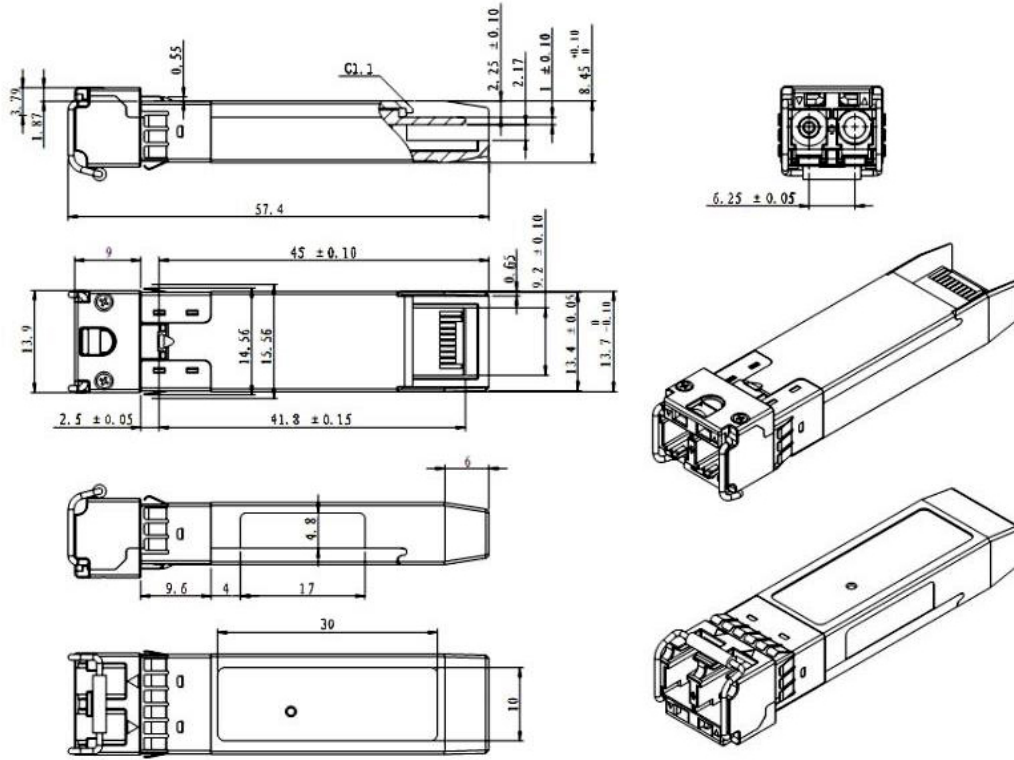

4NSYS Co., Ltd.

3F Hana Bldg, 118-2 Oryu-Dong, Guro-Gu, Seoul, Korea, 152100, Korea (South)
 Tel : +82-2-2685-7300 Email : sales@4nssystem.com
www.4nssystem.com



South Korea



© Copyright 1991 4NSYS Co., Ltd.
 4NSYS and the 4NSYS logo are trademarks of 4NSYS Co., Ltd.
 All rights reserved. All other trademarks are the property of their respective owners.