

4N-710K

30W Weatherproof Horn Speaker (Music Horn)



4N-710K is a waterproof horn speaker built-in 70v/100v transformer. The 70v/100v transformer technique reduces line losses on longer distance and allows easy parallel connection of multiple loudspeakers

The built-in 6"+3" two ways speaker drivers are designed of wide frequency response 90-20kHz, the multiple power taps 3.5W, 4.5W, 9W, 12.5W, 25W & 30W are helpful for different applications varies from room size and ambient noise surroundings.



Key Features

- Network Interface 10/100 Base-TX, RJ45 PoE
- 48 kHz, MP3 44.1 kHz, G.722 16 kHz, G.711 8 kHz, G.711 8 kHz
- Built-in 100v/70v transformer
- Waterproof horn type loudspeaker
- Wide frequency response range both suitable for music and paging
- Background music
- 6"+3" two ways speaker unit
- IP66 waterproof level
- Power taps 3.5w-4.5w-9w-12.5w-25w-30w @100V
- Signal to Noise Ratio
- Password protection, IP address filtering, Digest authentication, User access log, firewall
- Operating Temperature -30°C ~ +60°C
- Network Protocol HTTP, IPv4, DHCP, RTSP, RTP, RTCP, TCP, UDP, ARP, SIP, FTP, ONVIF, FTP, NFS, NTP

Product Specifications

Model	4N-710K
Power Taps @100V	3.5W, 4.5W, 9W, 12.5W, 25W, 30W
Power Taps @70V	1.75W, 2.25W, 4.5W, 6.25W, 12.5W, 25W
Impedance	Black: Com Red White: 2.9KΩ Yellow White: 2.2KΩ Red Green: 1.1KΩ Green White: 800Ω Yellow Green: 400Ω Red Yellow: 200Ω
Input	70V/100V/8Ω
SPL(1W/1M)	99dB±3dB
Max. SPL (Rated W/1M)	116dB
Frequency Response (-10dB)	90-20KHz
Finish	Baffle: ABS
Speaker Driver	6" x 1 3" x 1
IP Rate	IPx6
Dimensions	360 x 255 x 315mm
Weight	2.5Kg
Mounting	With mounting bracket fixed by screw

Dimensions

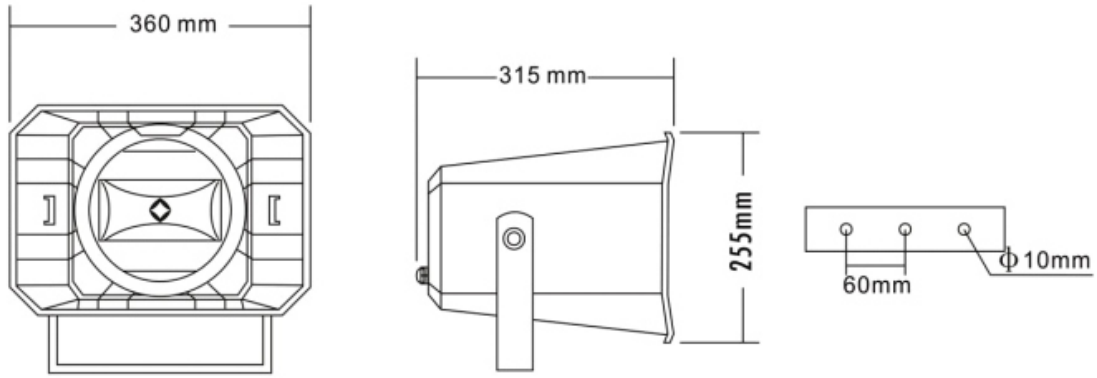

Direction Diagram

